

**SDH-4PB Digital Thermostat with LED display and Powerful Relay**

Electronic, digital thermostat designed for Heating and/or Cooling.



Front view of the standard SDH-4PB controller (with Grey and Black face plate). The LED display colors available in Red, Green or Blue.

This controller has an internal, accurate, programmable thermostat processor, that is self calibrating and does not require any maintenance or adjustments.

One external temperature sensor probe is connected via a screw terminal located on-board. Some models may have also a second sensor wired up for special functionality, like for instance to control the temperature difference at two separate locations.

The standard model can control one on-board relay to maintain the temperature level as preset by the user. In some models more relays may be installed as well.

Typically, when the thermostat is not running, the on-board relay is de-energized.

The thermostat has an "Anti-Cycle" function built in, that prevents the relay from switching too frequently, when the temperature is near the switching point.

Some models can also contain an internal, programmable timer that allows the user to set the thermostat to operate for a preset period of time in seconds, minutes, hours or days.

This controller is designed for 100% duty operation.

The temperature setpoint is programmable via the UP and DN keys on the face plate.

The user preset values and settings are retained in the internal, non-volatile memory.

Models available with temperature preset ranges from -40F ( -40C ) to +255F ( +124C ) or ranges from -60F ( -50C ) up to 960F ( 515C ), depending upon the controller model and the sensor probe used.

Custom temperature ranges, modes of operation and probe types are available upon request.

The ON/OFF key, when pressed, will Start or Stop the thermostat.

Normally, after the power-up the display will indicate the sensed temperature. In some models however the initial display can indicate "OFF", the preset setpoint or another data, as requested by

customer specifications. In standard models pressing the ON/OFF key will automatically preset the controller to the most recent setting, the maximum temperature or a custom Default Value, depending upon the selected mode of operation.

During the operation the display shows the current temperature reading and every several seconds it will show the preset target value. A flashing "." or "On" sign indicates that the thermostat is active. Other types of display sequences are available for customized models.

NOTE, that the thermostat features are customizable and may be ordered with different functionality.

Using a special procedure the user can modify many features of the controller, including the temperature ranges, the limits and the modes of operation.

There are many other options available for this controller. See the "List of Options" document for details.



SDH-4PB Thermostat with Semi-Flush face and with Black Label.



SDH-4PB Digital Thermostat Set including the Sensor Probe, in-line fuse holder and the mounting hardware. Semi-Flush face shown.



Flush face plate with Grey Label.



SDH-4PB Thermostat with Vandal Proof Push-buttons

**Temperature Sensor PROBE:**

A number of standard Temperature Probes is available for this controller, depending upon the application. Most probes are small in size. The most popular is a probe appx. 25 mm long and 5 mm in diameter ( 1"lg. x 0.2" dia. ). The probes have two thin wires attached at one end. The other end is sealed and can withstand exposure to unlimited moisture.

The wiring may be extended with *any type of a 2-conductor cable* up to appx. 150 m ( 500 ft. ).

Standard thermistor probes have 1% accuracy and the operating ranges vary from -40F to +255F (-40C to +124C) up to -60F to +960F (-50C to +515C) with special thermistor or RTD probes.

The probes are enclosed in a non-corrosive housing that may be Stainless Steel, chrome plated, black anodized or brass with two PVC or Teflon jacketed leads, sealed with epoxy resin at the wire end to prevent moisture penetration.

Note, that it is advisable to protect the leads with additional coat of, for instance, silicon sealant against possible excessive moisture condensation.

**Electrical:**

SDH-4 controller models are available for 120Vac, 208-250Vac, 12Vac, 24Vac, 50Hz /60Hz, as well as 12V or 24V DC. The supply voltage must be specified when ordering. The controller electronics is protected by one 20 mm, removable fuse that should be installed in the included in-line fuse holder or in clips on the controller PCB.

Standard models have one on-board relay, SPST, Normally Open. The relay can switch loads up to 30Amp, 250Vac max. ( 40 Amp is optional ). The contacts of the relay can be completely isolated from the controller supply, depending upon the chosen method of wiring.

Some models may have a small, low power relay installed, with contacts rated at 1Amp/250V max.

**Options:**

Various additional options are available for the SDH-4 controllers, including:

- |  |  |
|--|--|
| <i>Stand-by Preheat,</i>                       | <i>Heating or Cooling,</i>                     |
| <i>Temperature Difference Control</i>          | <i>Operation with One or Two Sensor Probes</i> |
| <i>Proportional control,</i>                   | <i>Permanent or Programmable Cycle Timer,</i>  |
| <i>Permanent or Programmable High Limit,</i>   | <i>Permanent or Programmable Low Limit,</i>    |
| <i>Adjustable Differential ( hysteresis ),</i> | <i>Remote Start/Stop or Enable,</i>            |
| <i>Alarm Buzzer, etc...</i>                    | <i>Remote Pause ( temporary stop )</i>         |

See the complete "List of Options" for details.

Many Temperature and Operating ranges, as well as various types of relays and wiring methods can be supplied upon the customer request.

**Installation:**

SDH-4 controllers are normally shipped without enclosures (optional) and are designed to fit in a standard 1-gang electrical box or in a panel.

Two types of face plates are available for Semi-Flush or Flush mounting.

The front plastic overlay with keys can be installed on either a customer supplied face plate or the standard Mounting Plate included in the kit. All mounting hardware, screws and wiring connectors are included. When correctly installed, there are no screws visible on the face plate.

**Applications:** Sauna Control Panel, Heaters, Coolers, Steam Rooms, Spa, Smokers, Yoga Room, Solar Heating, Freezer, Wine Cellar, etc...

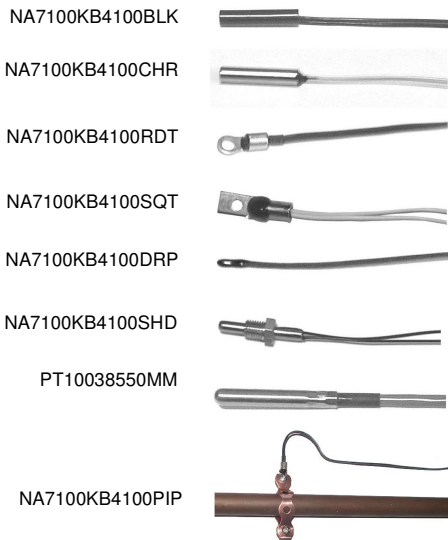

Variety of available temperature sensor probes.

NA7100KB4100SSFLG

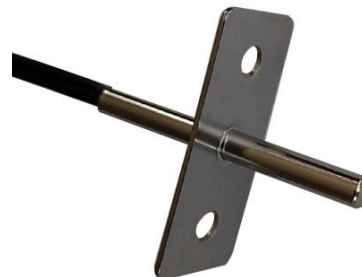

Temperature sensor probe with Flange

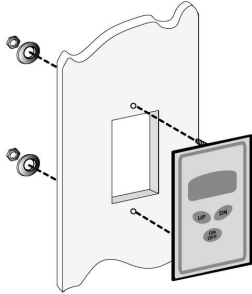

INSTALLATION EXAMPLE: FLUSH IN A WALL

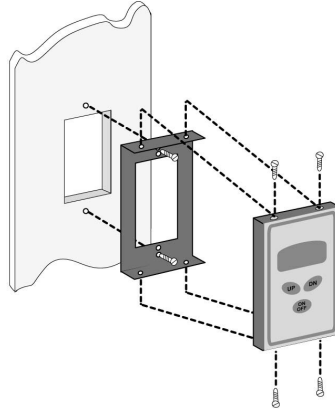

INSTALLATION EXAMPLE: SEMI-FLUSH IN A WALL



PPB-1 REMOTE START/STOP PUSH-BUTTON

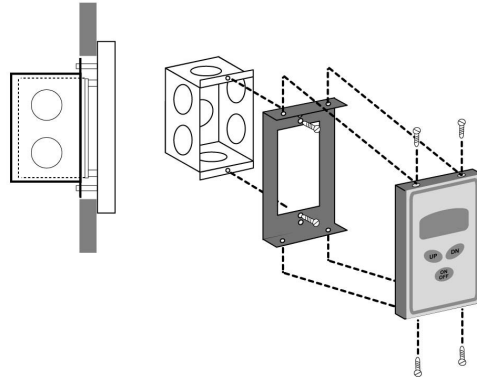

INSTALLATION EXAMPLE: SEMI-FLUSH IN A BOX



OPTIONAL SENSOR PROBE PLATES  
( PLASTIC PPP-4 or STAINLESS STEEL PPS-4 )



OPTIONAL SENSOR PROBE PROTECTIVE SHIELD ( PG-5 )

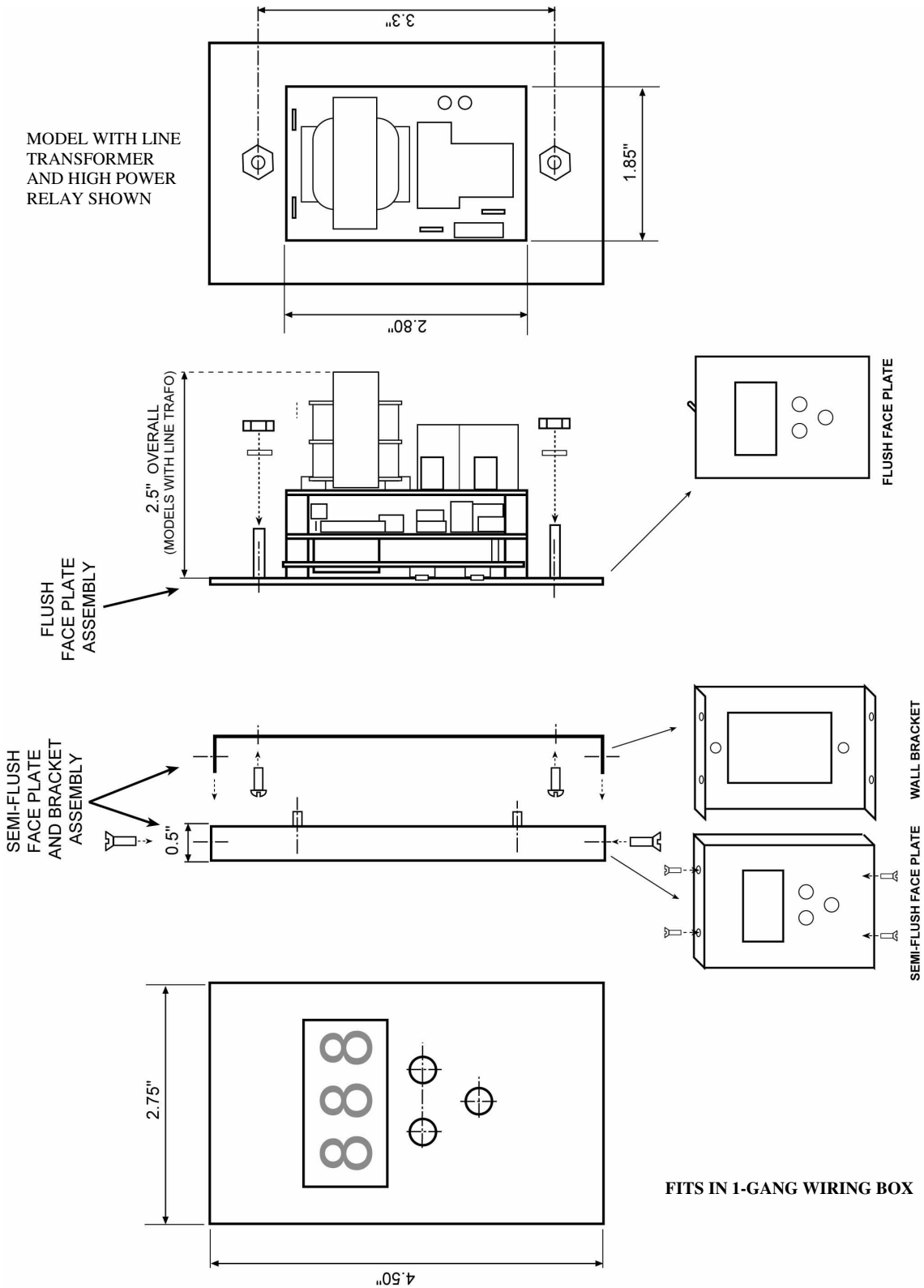

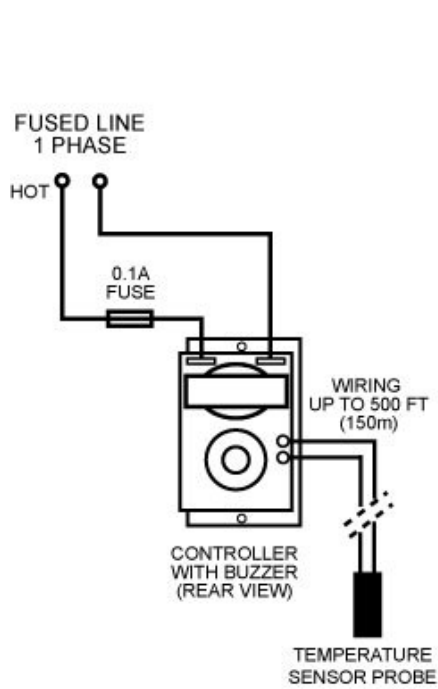

WIRING EXAMPLE WITH ON-BOARD BUZZER

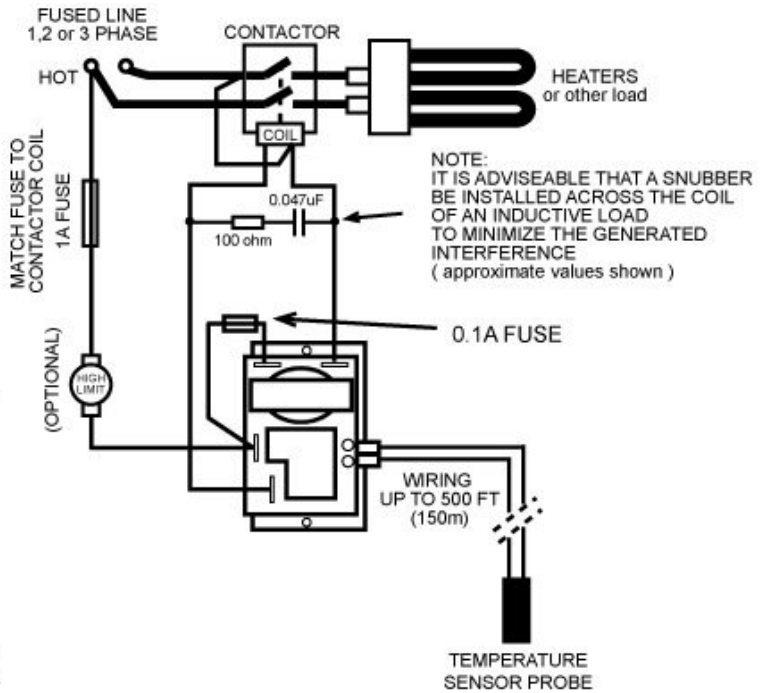

WIRING EXAMPLE WITH EXTERNAL CONTACTOR  
TO BOOST THE LOAD POWER

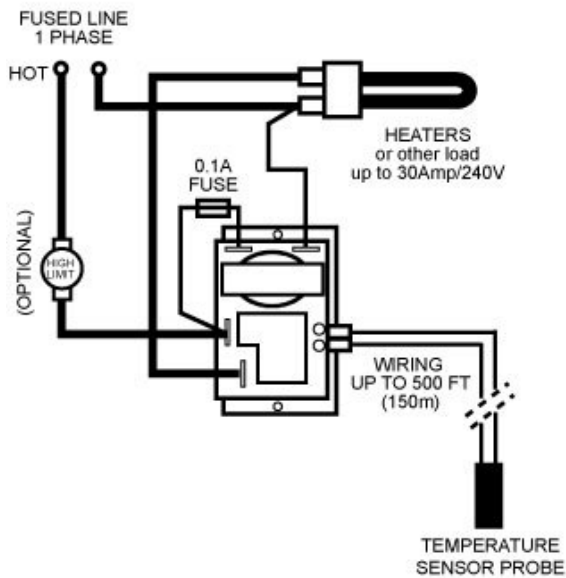

WIRING EXAMPLE WITH POWER LINE SUPPLY  
COMMON FOR THE CONTROLLER AND THE LOAD

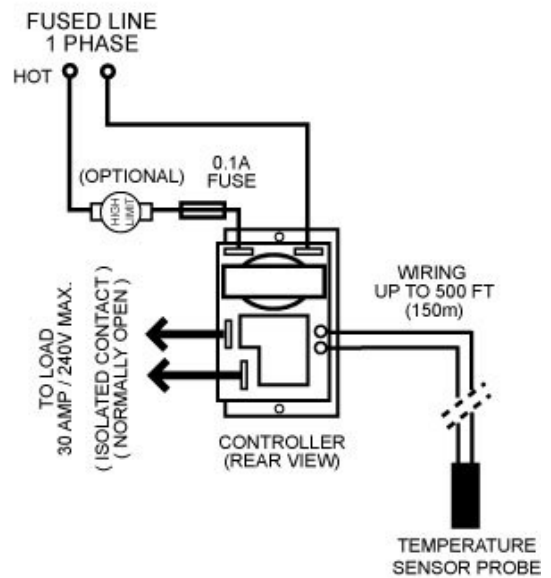

POWER LINE SUPPLY  
SEPARATE FOR THE CONTROLLER AND THE LOAD

*OPERATING INSTRUCTIONS ( example for standard models ):*

HOW TO START and STOP :

Press the "ON/OFF" key to Start or Stop the thermostat. At Start the display will show the current preset. When the thermostat is ON, the display will indicate the current temperature reading and every several seconds it will flash the temperature preset value.

Note, that depending upon the model, the thermostat may start automatically on power-up or it may require manual pressing of the ON/OFF key, or it may resume the state at which it was when the supply power was interrupted.

TEMPERATURE ADJUSTMENT :

Press the UP or DN key to preset the desired target temperature.

NOTE: For as long as the supply power is present, the preset value is saved in internal memory and it may be recalled later on by pressing a key on the keypad. Note, that after each new Power Up the Preset is automatically set to the most recent preset, the maximum or the default value, depending upon the particular controller model and the selected mode of operation.

*CELSIUS / FAHRENHEIT SELECTION :*

To switch between the Celsius and Fahrenheit units, press both; the UP and DN keys simultaneously. In some models the units may be permanently set or can be altered using a different method.

CONTROL OPERATION :

The Controller switches the load ON and OFF, as required to maintain the preset temperature, as compared to the sensor reading.

AUTOMATIC STOP :

The Controller stops automatically when a malfunction is detected or the temperature exceeds the controller limits.

IDLE/MONITORING OPERATION :

When the controller is at OFF, the display will indicate "OFF", or it may show the current temperature reading and every several seconds show the text "OFF", depending upon the controller model. The load is switched OFF.

**CAUTION:**

**All installation and adjustments of the controller options MUST be done ONLY when ALL POWER to the load and the controller is disconnected.**

TROUBLESHOOTING :

Sensor wiring and controls are continually checked for proper operation. If a malfunction is detected, the controller will automatically switch OFF the load and deactivate itself. At the same time the display will show the text "Err" and may also indicate other messages, depending upon the controller model.

The controller can not be reactivated until all causes of the malfunction are fixed.



Following is an example of specifications for a selected model. Note that all Thermostat ranges, electrical as well as mechanical specifications may be modified to the customer requirements or via the special setting procedure.

Example model: **SDH-4PB-HP-120-H1-FN40P255-RFN40P254...**

<b>SPECIFICATIONS:</b>	<b>VALUE</b>	<b>NOTES, COMMENTS</b>
<b>Electrical:</b>		
Supply Voltage:	105-130Vac, 50/60 Hz	208-250Vac, 50/60Hz, 12/24V AC/DC
Supply Current (controller):	25 mA RMS max.	May be lower for different voltages, relays and display brightness or color
Max. Switched Load:	30 Amp, 240Vac max.	May be different for other relay models
Switching Reliability:	10,000,000 electrical 10,000,000 mechanical	For AC load
Switching Anti-Cycle:	10 sec. On ON action	May be preset to other value on request
Oper. Ambient temperature:	-4 to +158F (-20 to +70C ) (standard)	-20 to +90C extended with high temp LEDs
Control temperature:	-40 to +255F (-40C to +124C) (standard)	May be extended up to 960F ( 515C )
Temp. Preset Range:	-40 to +255F (-40C to +124C )	Other ranges available
Temp. reading accuracy:	+/- 1%	Over the operating range
Hysteresis (differential):	+1F, -0F (+0.5C, -0C )	May be set to any value on request
Temp. Display resolution F:	1 F	Other available on request
Temp. Display resolution C:	1 C	Other available on request
Probe Temperature Range:	-40 to +255F (-40 to +124C ) (standard)	Extended temp. avail. on custom orders
Probe wiring distance:	500 Ft. (150 m ) max.	May be extended on special order
Probe dimensions:	1" x 0.2" dia ( 25mm lg. x 5mm dia. )	Chrome plated or other probes per request
LED Display:	3 digits, 0.56" high	
Display color:	Super RED, GREEN or BLUE	Different colors upon request
<b>Mechanical:</b>		
Face plate:	Painted Metal	Flush or Semi-Flush mounted face plate
Face plate dimensions:	2.75" x 4.5" ( 70mm x 115mm )	
Mounting Bracket:	Metal, baked powder paint	Semi-Flush , depending upon the model
Mounting bracket dimensions:	2.7" x 4.45" ( 69mm x 113mm )	For Semi-Flush models
Controller dimensions::	2.85" x 1.85" x 2.3" (HxWxD) ( 73mm x 47mm x 58mm )	Models with transformer
Overall weight:	300 gm	Models with transformer
Shipping Packaging:	Carton with bubble padding	
Accessories pack:	Mounting screws and nuts, if needed Face plate, Bracket and Lexan decal: 1 pc each In-line fuse holder + 20mm fuse: 1 pc	